

# Lead-Free\* Brass Ball Valves - Threaded

Two-Piece Body • Full Port • Blowout-Proof Stem • PTFE Seats



**600 PSI Non-Shock Cold Working Pressure**

- NSF/ANSI 61-8 (INCLUDES ANNEX F & G)
- NSF/ANSI 372 • IAPMO IGC-157 • MSS SP-110

## MATERIAL LIST

PART	SPECIFICATION
1. Body	Forged DZR Copper Alloy
2. End Cap	Forged DZR Copper Alloy
3. Ball Seat	PTFE
4. Ball	Stainless Steel or Chrome Plated Brass
5. Stem	Brass
6. O-Ring (Stem Seal)	Fluorocarbon (FKM)
7. Stem Packing	PTFE
8. Packing Nut	Brass
9. Lever Handle	Steel, Plated
10. Drain Cap	Brass
11. Seal	Buna-N



**T-FP-600AD-LF**  
w/Drain

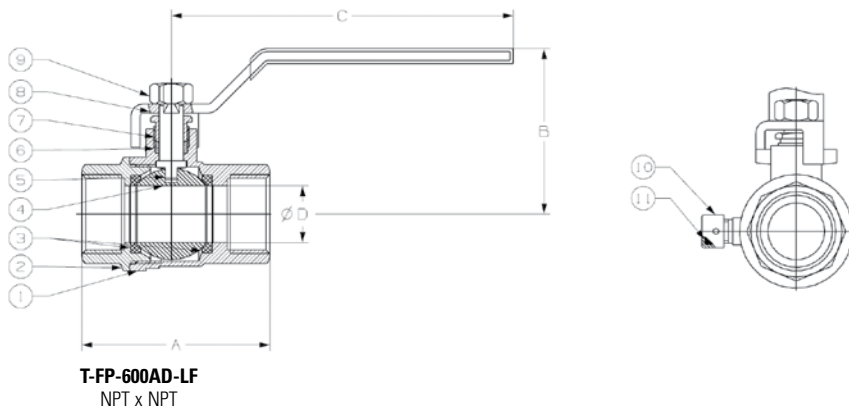

## DIMENSIONS—WEIGHTS—QUANTITIES

Size		A		B		C		Port D				Ctn. Qty.
In.	mm.	In.	mm.	In.	mm.	In.	mm.	In.	mm.	Lbs.	Kg.	
1/2	15	2.18	55	1.67	42	3.54	90	0.58	15	0.48	0.22	18
3/4	20	2.48	63	2.14	54	4.47	114	0.75	19	0.75	0.34	12

\*Weighted average lead content ≤ 0.25%